

VERTIFLO

SERIES 1400 BASE MOUNTED END SUCTION PUMPS

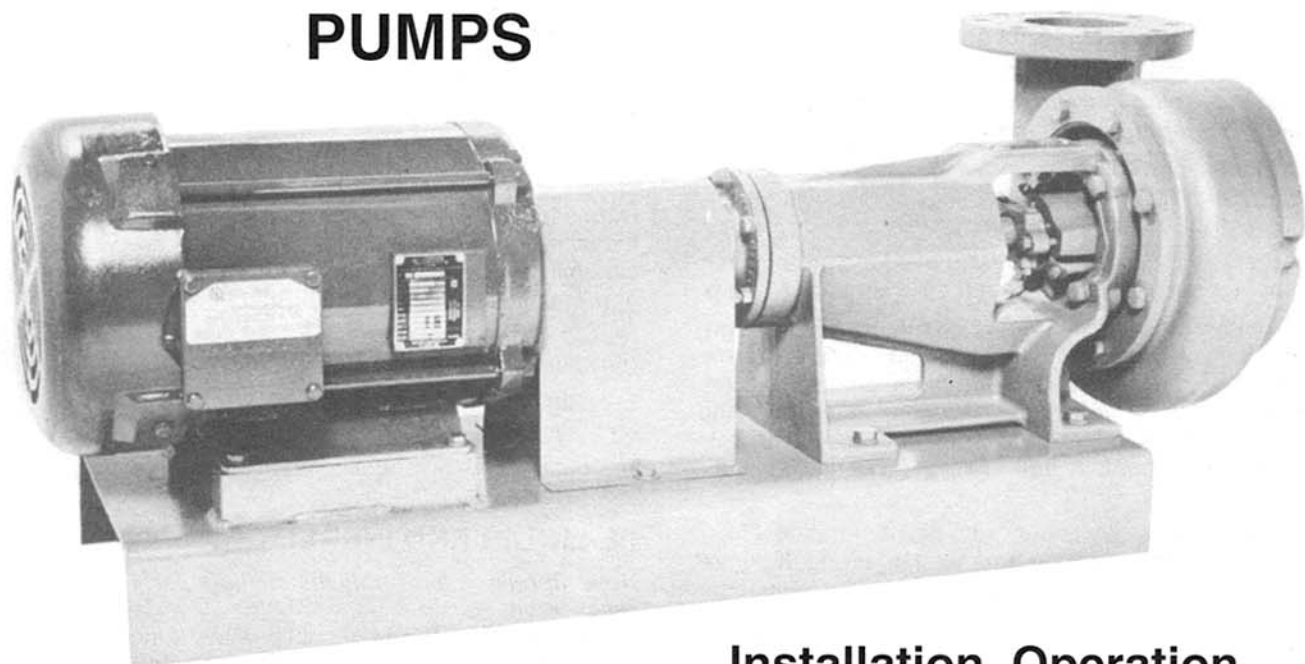

**Installation, Operation
& Service Instructions**

IMPORTANT HANDLING INSTRUCTIONS

Lifting equipment should be placed under Pump Base only.

I. INSTALLATION INSTRUCTIONS

VERTIFLO horizontal, base-mounted pumps are completely assembled, carefully adjusted and prelubricated at the factory before shipment.

- A. Carefully set pump at the required location. Check for full contact of the motor base to the foundation.
- B. Secure pump to foundation by bolting, etc.; whatever is convenient or required for the installer.
- C. Connect the system piping to the pump; suction piping to the flange at the end of the pump and discharge piping to the flange which is part of the casing (51). A check valve and gate valve should be installed in the discharge piping and a gate valve in the suction piping. An elbow in the suction piping should not be closer to the pump than the equivalent of 5 times the suction pipe diameter.

Note: All piping is to be supported independent of the pump. No piping strain is to be imposed on the pump.

- D. Connect power lines to motor leads as shown on the wiring diagram of the motor for specific line voltage used. Follow all state and local wiring codes.
- E. Check and be sure starter and overload protection is proper for specific voltage and for the amperage rating.
- F. Remove coupling guard and **check coupling, alignment**. Check for free rotation. If binding occurs, remove coupling rubber sleeve, and turn pump shaft. If binding is determined to be caused by the pump, check for piping strain or impeller adjustment (see Impeller Adjustment--(Section III)). If pump is free rotating, recheck coupling alignment.

G. Jog motor quickly to check for proper rotation. Rotation is clockwise when looking from the motor end. If pump rotation is incorrect, contact a qualified electrician to make necessary corrections. After correct rotation is obtained, reinstall coupling guard.

H. Open suction line gate valve. Close discharge line gate valve and start pump. Open discharge line valve SLOWLY until desired capacity is obtained. Pump should now operate smoothly. If vibration occurs, check for pipe stress.

I. Packed pumps are shipped with loosely adjusted glands (25). If excessive leakage occurs, evenly tighten the two packing nuts until leakage is a drip.

NOTE: Do not tighten packing gland until all leakage stops. Packing must have some leakage for lubrication. Overtightening will burn packing and score the shaft.

II. LUBRICATION

Series 1400 pumps are properly lubricated at the factory. Further on-site lubrication schedules depend upon local operation conditions. It is recommended that all bearings and packing be periodically inspected and greased.

- A. Thrust bearing (6), radial bearing (7), and packing (22) should be greased every two or three months.
- B. Lithium base grease with corrosion inhibiting properties should be used.

C. Motor should be lubricated in accordance with manufacturer's recommendations

III. IMPELLER ADJUSTMENT

Impeller adjustment is accomplished by moving the bearing cap assembly located at the shaft end of the pump. On the bearing cap is located two sets of capscrews: 3 capscrews with nuts (15, 16) which are the jackscrews and 3 capscrews (17, 18) which are threaded into the powerframe (13).

- A. Loosen coupling set screws and slide coupling halves apart.
- B. Loosen the 3 nuts (16) on the jackscrews (15) until they are against the jackscrew heads, then unscrew the jackscrews several turns.
- C. Evenly tighten 3 capscrews (17, 18) until the shaft can no longer be turned by hand. The impeller is now forward against the suction head (52).
- D. Loosen the capscrews (17,18) a couple of turns. Turn the jackscrews (15) until they touch the powerframe. Carefully alternate tightening them approximately 1/4-1/2 turn or until the shaft can be turned freely by hand.

NOTE: On Model 1424, make sure that an even spacing is maintained between the bearing cap and the powerframe.

- E. Retighten the 3 capscrews (17, 18) and the 3 nuts (16) on the jackscrews.
- F. Reassemble the coupling and tighten the set screws.

IV. LIQUID END INSPECTION

Note: Before disassembly match mark parts for ease in reassembly.

- A. Turn off electrical supply of the motor and all controls. Shut suction line and discharge line gate valves. Remove drain plug from casing and drain unit.
- B. Remove coupling guard. Remove rubber insert from coupling after sliding coupling halves up their respective shafts.
- C. Remove the four capscrews in the powerframe feet.
- D. Remove capscrews (55) holding case adaptor to casing.
- E. Pull powerframe (13) toward motor, turning to clear the motor shaft end, leaving the casing (51) connected to the piping. **NOTE: DEPENDING ON THE STYLE OF COUPLING, IT MAY BE NECESSARY TO TURN THE MOTOR ON ITS BASE TO CLEAR SHAFTS.**
- F. To remove impeller (2), straighten cotter pin (3A) and remove from castellated impeller nut (3). Unscrew impeller nut (3) by turning counterclockwise while holding coupling with strap wrench. Remove impeller washer (4).
- G. To remove impeller (2), from the shaft (1), use three fully threaded capscrews 1/2"-13NC x 2 1/2" long as jackscrews in the threaded holes in the impeller shroud. The capscrews will thread in approximately one inch before contact with the packing box (21). Tighten until impeller is forced off the tapered shaft.
- H. Remove impeller key (5).

V. BEARING AND FRAME DISASSEMBLY

FOLLOW LIQUID END INSPECTION DIRECTIONS-- SEE SECTION IV.

- A. Remove the four capscrews holding the packing box or seal head, and case adaptor (56) to the powerframe (13).
- B. Remove case adaptor (56).
- C. Remove packing box or seal head (21). Depending on the condition of the shaft and packing, it may be necessary to remove the packing before removing the packing box

**IF PUMP IS SUPPLIED WITH A MECHANICAL
SEAL FOLLOW MANUFACTURER'S
RECOMMENDATIONS**

- D. Remove slinger (20).
- E. Remove three capscrews (17, 18) and jackscrews (15) from bearing cap (8). Using a rubber mallet, gently drive the shaft and bearing car assembly from the powerframe by striking the impeller end of the shaft.

**BE CAREFUL NOT TO DAMAGE THE THREADS
ON THE END OF THE SHAFT.**

- F. To remove the bearing cap from the shaft assembly, remove the large snap ring (11) from the bearing cap (8). The bearing cap can now be removed.

BE CAREFUL NOT TO DAMAGE THE LIP SEAL (12).

- G. Remove the snap ring (10) from the shaft.
- H. The bearings can now be pressed off the shaft.

VI. REASSEMBLY OF BEARINGS AND POWERFRAME

- A. Press thrust bearing (6) into position with the shield side toward the large diameter of the shaft. Install small snap ring (10) with the chamfered face away from the bearing.
- B. Install lip seal (9) into the bearing cap (8) with the spring side facing toward the bearing area.
- C. Slide bearing cap over the thrust bearing until bearing is fully seated. Install snap ring (11) with the chamfer face away from the bearing.
- D. Press on radial bearing (7) with the shield facing toward the large diameter of the shaft.
- E. Install lip seal (12) into the powerframe (13) with the spring side toward the bearing area.
- F. Slide the shaft and bearing cap assembly into the powerframe until there is approximately 1/8" gap between the powerframe end and the flange on the bearing cap. Align non-tapped holes in the bearing cap with the threaded holes in the powerframe. If resistance is met as the cap is inserted DO NOT pound on the shaft. If it is necessary to drive the shaft and cap assembly, strike with a rubber mallet on the bearing cap.
- G. Install slinger (20) by sliding over shaft.
- H. If packed pump, slide gland (25) over the shaft to the slinger.

- I. Slide packing box or seal head assembly over impeller end of shaft until seated against powerframe.
- J. Place gasket (57) over packing and insert four capscrews into powerframe through packing box. The two longer screws go in the bottom two holes.
- K. Seat case adaptor (56) into packing box using capscrews to align holes and gasket. Tighten capscrews.
- L. Install packing or mechanical seal. If packed pump, install three rings of packing (22); next the lantern ring (23); then fill packing box with additional rings without overfilling. The cut edges of each packing ring should be placed 180 degrees from the previously installed piece. Slide the gland until it contacts the packing and install gland washer and nuts. Tighten finger tight. If sealed pump, install seal per manufacturer's recommendations.
- M. Loosely install capscrews (17, 18) and jackscrews (15) into the bearing cap.
- N. Install coupling key and pump half coupling.
DO NOT POUND ON COUPLING TO INSTALL.

VII. ASSEMBLY OF LIQUID END

- A. Install impeller woodruff key (5) and slide impeller (2) over shaft, aligning keyway to key.
- B. Install impeller washer (4) and impeller nut (3); tighten impeller nut. When close to tight, align slot in castellated nut with drilled hole in end of shaft. Install cotter pin (3A) and bend ends to secure.
- C. Install gasket (54) on case adaptor (56).
- D. Slide powerframe assembly into casing (51).
**NOTE: BE CAREFUL NOT TO FORCE
POWERFRAME INTO CASING. CASING MAY
HAVE SHIFTED DUE TO PIPE STRAIN. IF
THIS IS THE CASE, REALIGN CASING WITH
POWERFRAME.**
- E. Loosely install four capscrews in feet of powerframe. Install capscrews in case adaptor (56) and tighten. Tighten capscrews in powerframe feet.
- F. Readjust impeller as described in section.

III.-IMPELLER ADJUSTMENT.

- G. Reinsert coupling sleeve or insert, reassemble coupling and CHECK ALIGNMENT.
- H. Replace drain plug in casing.
- I. Replace coupling guard.
- J. Turn on electrical supply to motor.
- K. Open suction line and discharge line gate valves.

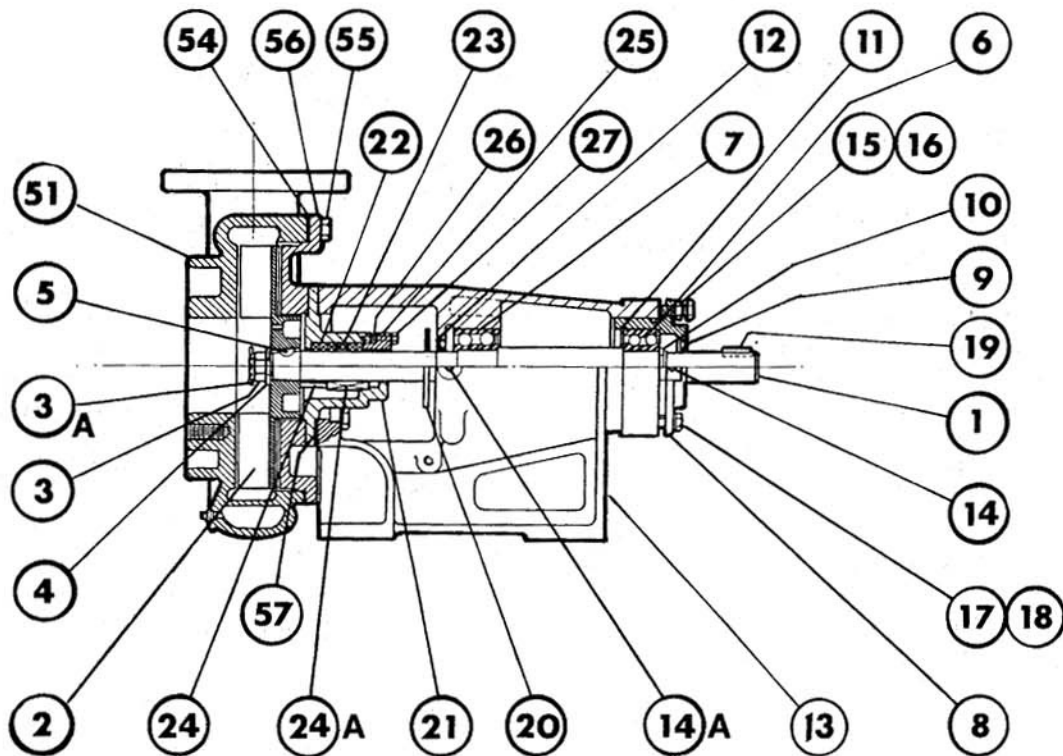

ITEM	DESCRIPTION	ITEM	DESCRIPTION
*1	SHAFT	17	CAP SCREW
2	IMPELLER	18	CAP SCREW
3	IMPELLER NUT	19	COUPLING KEY
3A	COTTER PIN	*20	SLINGER
4	IMPELLER WASHER	21	PACKING /SEAL HEAD
5	IMPELLER KEY	*22	PACKING
*6	THRUST BEARING	*23	LANTERN RING
*7	RADIAL BEARING	*24	SEAL SPACE SLEEVE
8	BEARING CAP	*24A	MECHANICAL SEAL
*9	LIP SEAL	25	PACKING GLANDS
*10	SHAFT SNAP RING	26	STUD
*11	CAP SNAP RING	27	STUD NUT
*12	LIP SEAL	27A	STUD WASHER
13	POWER FRAME	51	CASE
14	GREASE FITTING	*54	CASE GASKET
14A	GREASE FITTING	55	CAP SCREW
15	JACK SCREW	*56	CASE ADAPTOR
16	JACK SCREW NUT	57	STUFFING BOX GASKET

*Recommended Spare Parts

Refer to Pump Serial Number and Part Item Number when ordering parts.

VERTIFLO PUMP CO., INC.
7807 Redsky Drive
Cincinnati, Ohio 45249

VERTIFLO